

ITEM #	PART NUMBER	CONFIGURATION	REV	DESCRIPTION	MATERIAL	QTY
1	AS-4506-01	X0813S	A	08U x 13in. D Cube Wall Mount Side Panel		2

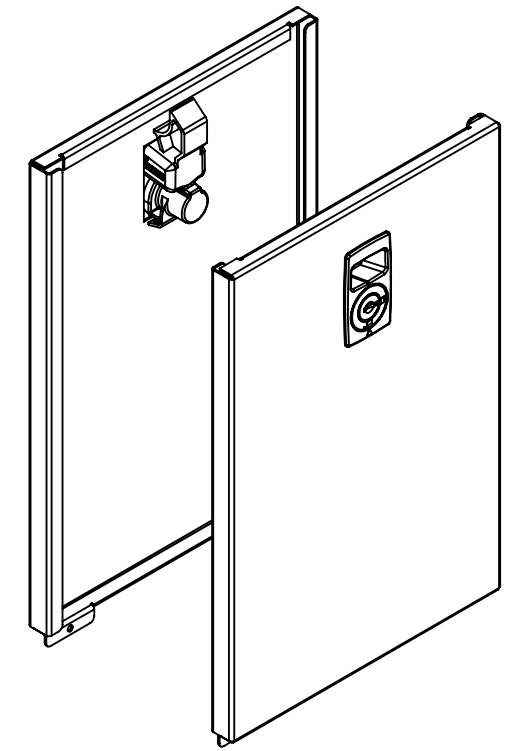
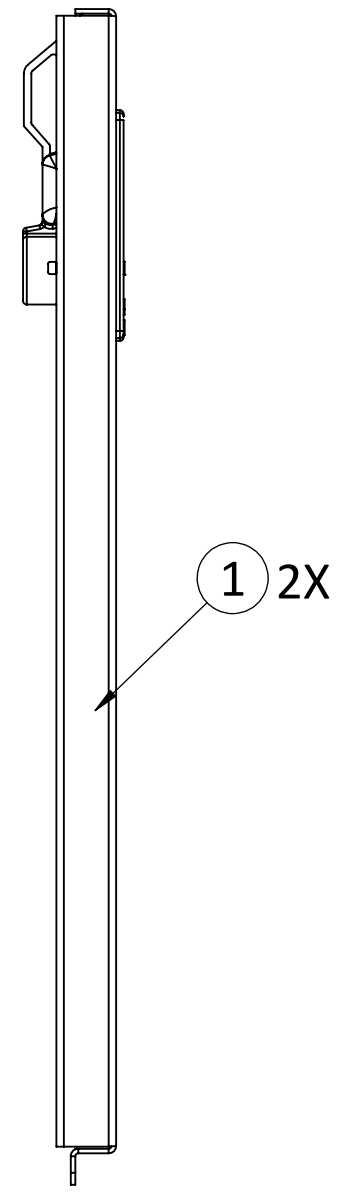
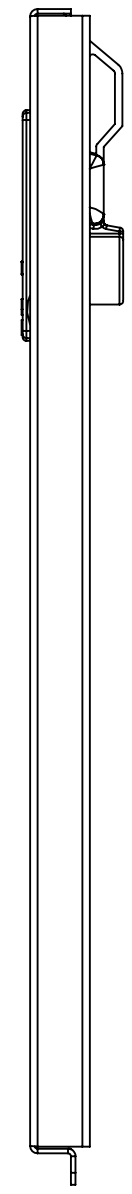
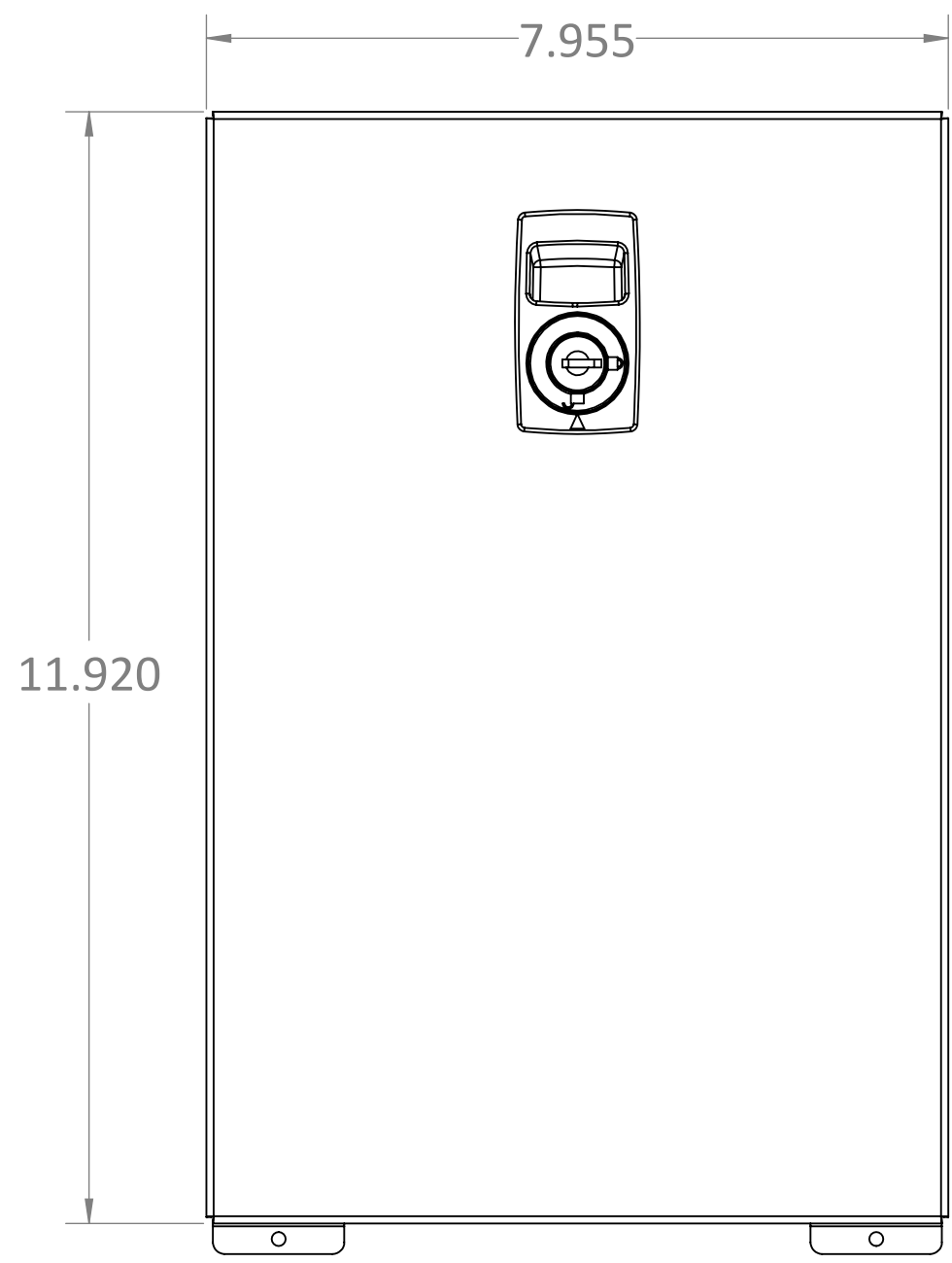

**RXL**  
 PROPRIETARY AND CONFIDENTIAL:  
 THE INFORMATION CONTAINED IN THIS  
 DRAWING IS THE SOLE PROPERTY OF RXL.  
 ANY REPRODUCTION IN PART OR AS A  
 WHOLE WITHOUT THE WRITTEN  
 PERMISSION OF RXL IS PROHIBITED.

SERIES/FAMILY NUMBER:  
**RXL-4506**

DESCRIPTION:  
**08U x 13in. D Cube Wall Mount Side Panel**

REVISION <b>A</b>	DATE <b>3/24/2020</b>	REVISION DESCRIPTION: Initial
----------------------	--------------------------	----------------------------------

CONFIGURATION (SEE TABLE DETAILS/"X" DENOTES COLOR):  
**X0813S**

COMMENTS/FOLDER PATH:  
 B:\RXL Inc\RXL Engineering - General\RXL\Section 4 - Wall Mounts\RXL-4506 Cube Wall Mount Side Panels\

UNLESS OTHERWISE SPECIFIED: DIMENSIONS ARE IN INCHES TOLERANCES: ±0.03 FRACTIONAL: ±1/32 ANGULAR: ±1° TWO PLACE DECIMAL ±0.03 THREE PLACE DECIMAL ±0.030	MATERIAL:	FULL PART NUMBER: RXL-4506-X0813S
	FINISH: <b>PAINT</b>	DRAWN BY: Jackson Chong
	WEIGHT:	DRAWN DATE: 3/24/2020
	SURFACE AREA:	DO NOT SCALE DRAWING Scale: 1:4
		DRAWING SIZE: <b>B</b> SHEET 1 OF 2

8	7	6	5	4	3	2	1
---	---	---	---	---	---	---	---

ITEM #	PART NUMBER	CONFIGURATION	REV	DESCRIPTION	MATERIAL	QTY
1	AS-4506-01	X0813P	A	08U x 13in. D Cube Wall Mount Side Panel		2

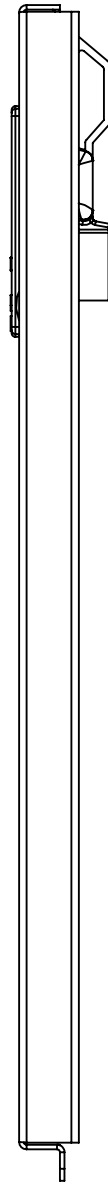
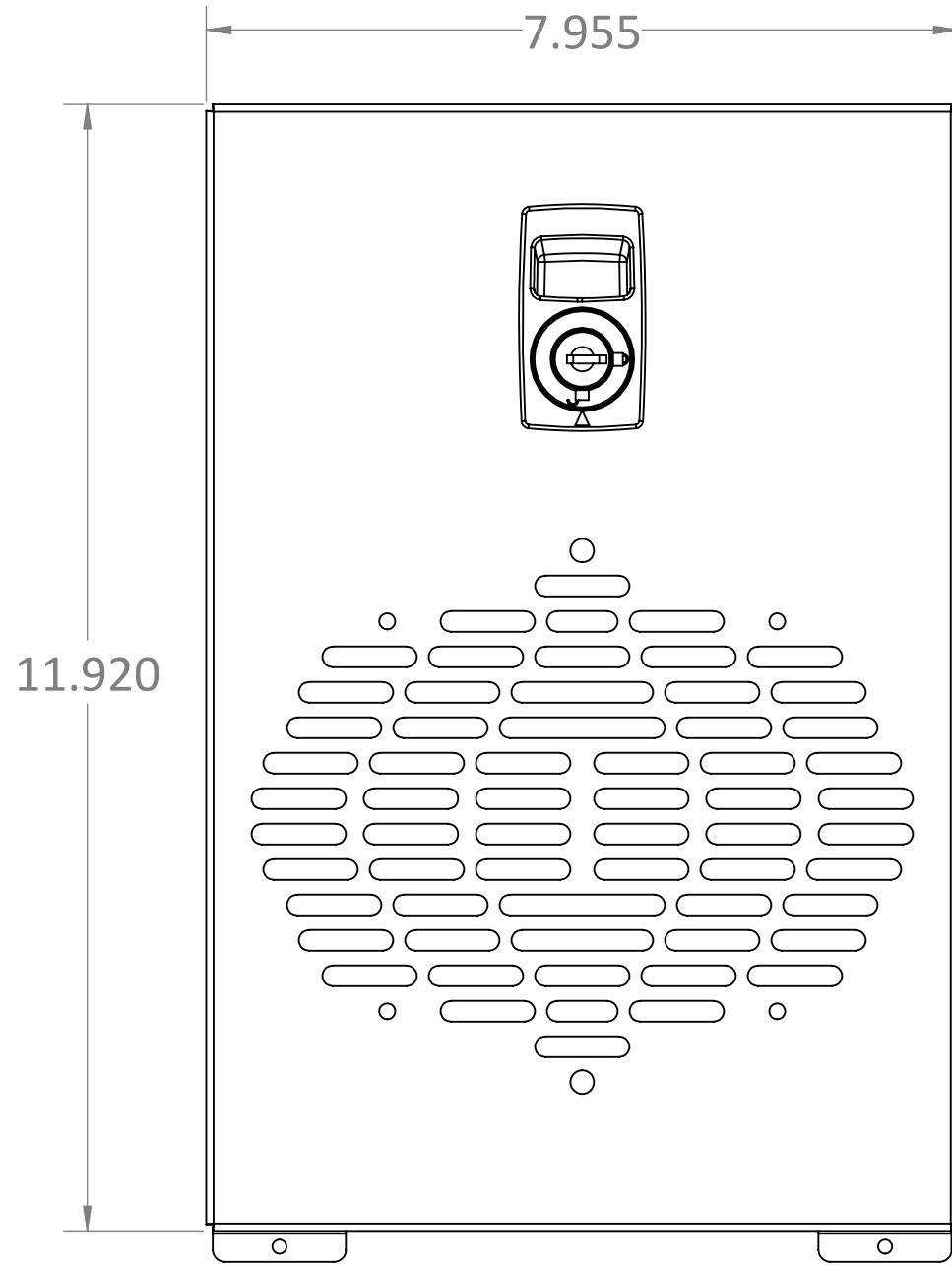

1 2X

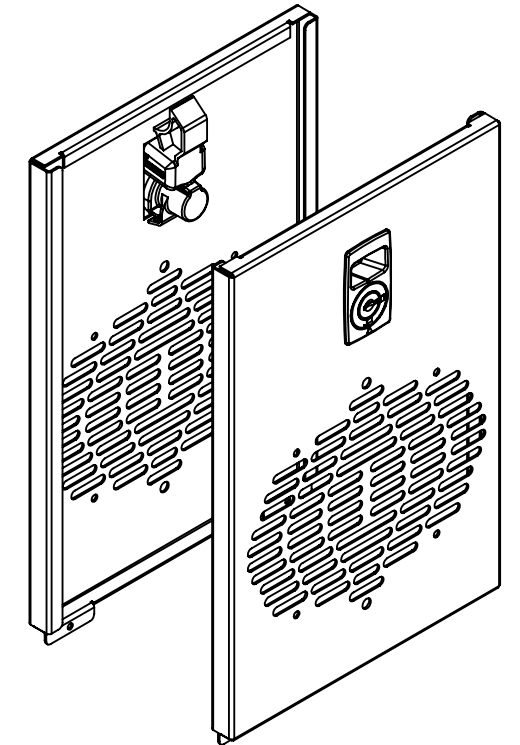

**PROPRIETARY AND CONFIDENTIAL:**  
THE INFORMATION CONTAINED IN THIS DRAWING IS THE SOLE PROPERTY OF RXL. ANY REPRODUCTION IN PART OR AS A WHOLE WITHOUT THE WRITTEN PERMISSION OF RXL IS PROHIBITED.

SERIES/FAMILY NUMBER:  
**RXL-4506**

DESCRIPTION:  
**08U x 13in. D Cube Wall Mount Side Panel**

REVISION  
**A**

DATE  
**3/24/2020**

REVISION DESCRIPTION:  
**Initial**

CONFIGURATION (SEE TABLE DETAILS/"X" DENOTES COLOR):  
**X0813P**

COMMENTS/FOLDER PATH:  
B:\RXL Inc\RXL Engineering - General\RXL\Section 4 - Wall Mounts\RXL-4506 Cube Wall Mount Side Panels\

UNLESS OTHERWISE SPECIFIED:  
DIMENSIONS ARE IN INCHES  
TOLERANCES: ±0.03  
FRACTIONAL: ±1/32  
ANGULAR: ±1°  
TWO PLACE DECIMAL ±0.03  
THREE PLACE DECIMAL ±0.030

MATERIAL:

FINISH:  
**PAINT**

WEIGHT:

SURFACE AREA:

FULL PART NUMBER:

**RXL-4506-X0813P**

DRAWN BY: Jackson Chong

DRAWN DATE: 3/24/2020

DO NOT SCALE DRAWING  
Scale: 1:4

DRAWING SIZE: **B**  
SHEET 2 OF 2