

| ITEM # | PART NUMBER | CONFIGURATION | REV | DESCRIPTION                             | MATERIAL | QTY |
|--------|-------------|---------------|-----|---|----------|-----|
| 1      | AS-3346-01  | X02           | B   | Horizontal Ring Panel Hardware Assembly |          | 1   |

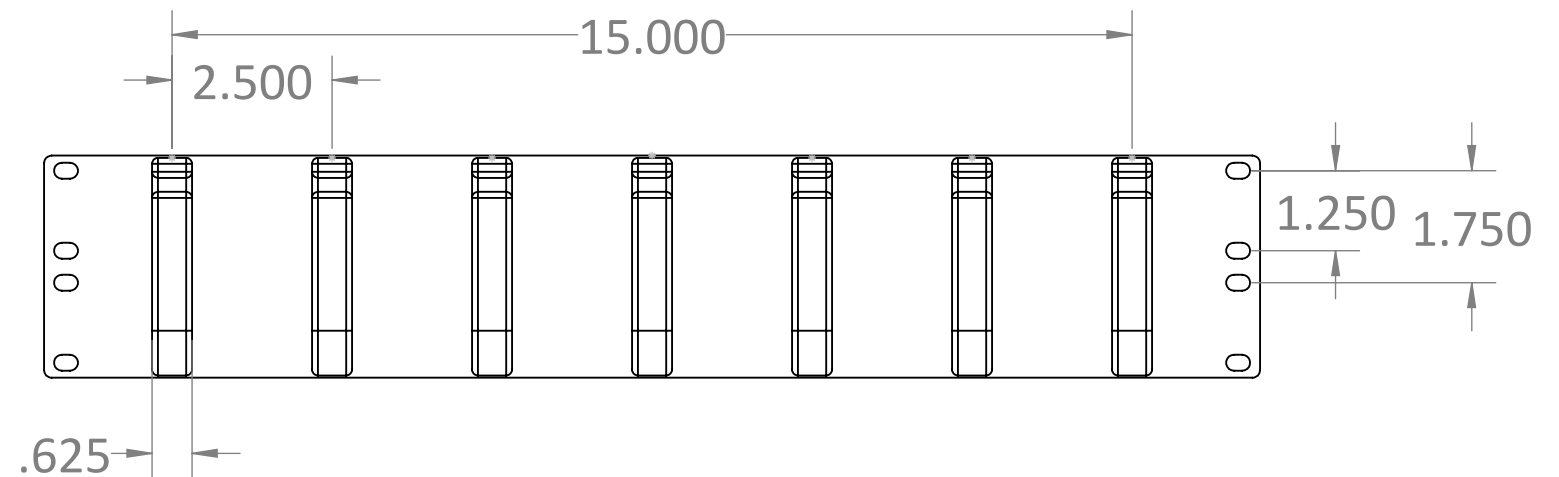
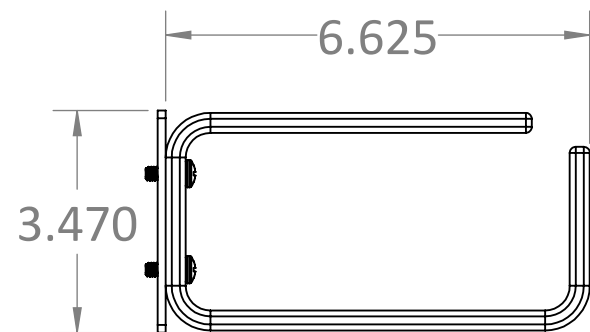
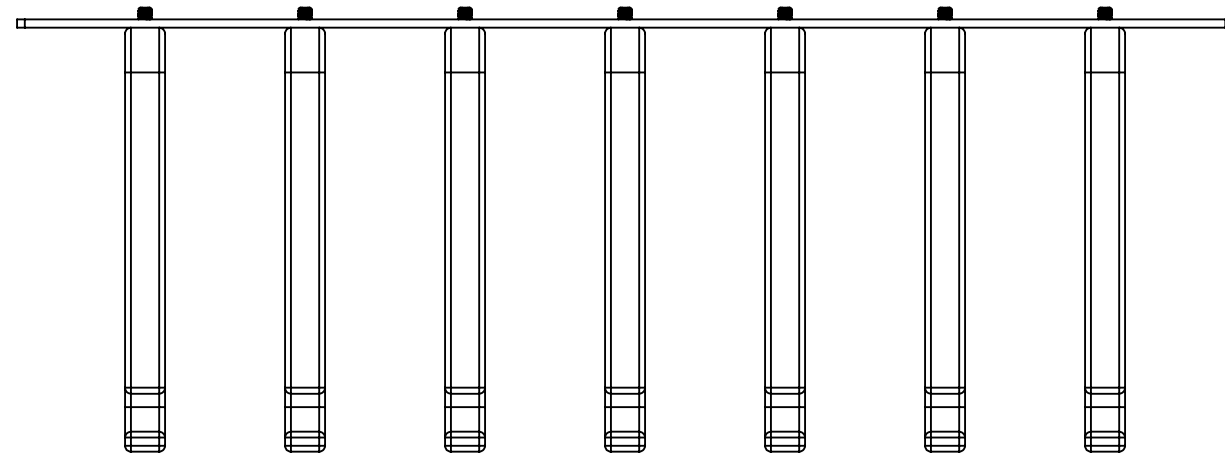
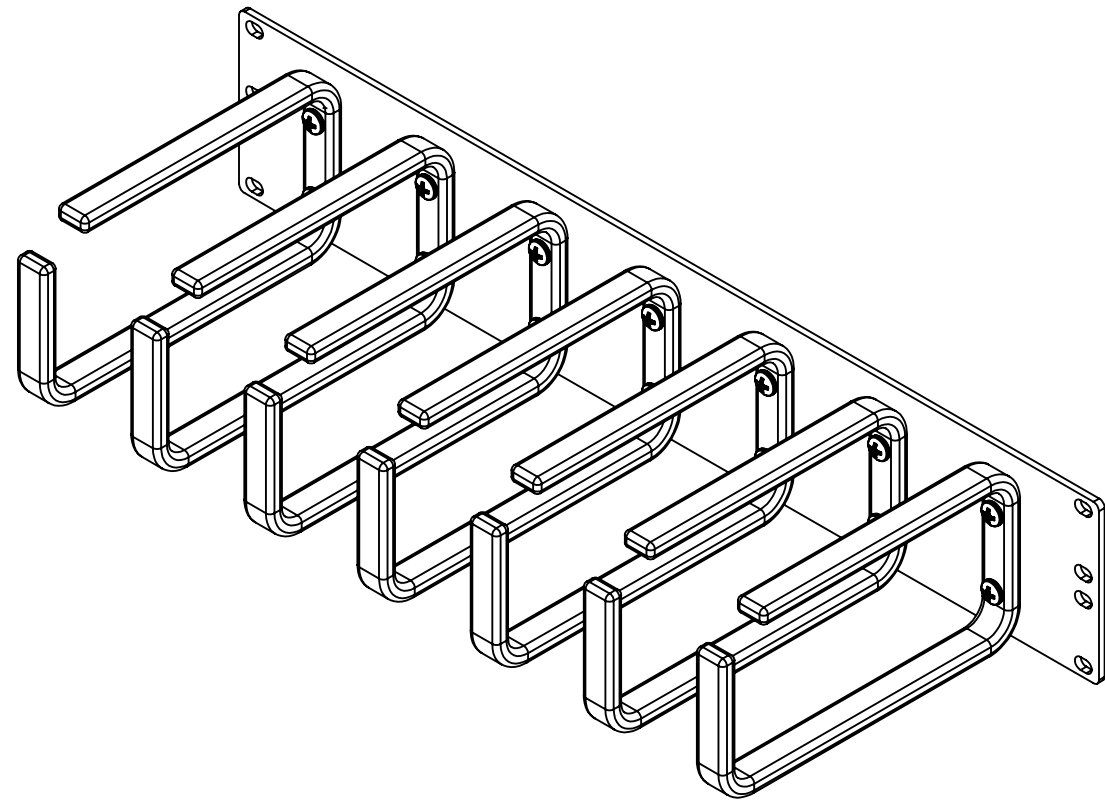

PROPRIETARY AND CONFIDENTIAL:  
THE INFORMATION CONTAINED IN THIS  
DRAWING IS THE SOLE PROPERTY OF RXL.  
ANY REPRODUCTION IN PART OR AS A  
WHOLE WITHOUT THE WRITTEN  
PERMISSION OF RXL IS PROHIBITED.

SERIES/FAMILY NUMBER:  
**RXL-3346**

DESCRIPTION:  
**RXL-3346 Horizontal Ring Panel**

| REVISION | DATE             | REVISION DESCRIPTION  |
|----------|------------------|-----------------------|
| <b>B</b> | <b>1/11/2023</b> | <b>Added New Size</b> |

CONFIGURATION (SEE TABLE DETAILS/"X" DENOTES COLOR):  
**X02**

COMMENTS/FOLDER PATH:  
D:\RXL Inc\RXL - Engineering - Documents\Section 3 - Cable Management\RXL-3346 Horizontal Ring Panel\

UNLESS OTHERWISE SPECIFIED:  
DIMENSIONS ARE IN INCHES  
TOLERANCES: ±0.03  
FRACTIONAL: ±1/32  
ANGULAR: ±1°  
TWO PLACE DECIMAL ±0.03  
THREE PLACE DECIMAL ±0.030

MATERIAL:  
FINISH:  
**PAINT**  
WEIGHT:  
**7.16lbs.**  
SURFACE AREA:  
**360.62in.<sup>2</sup>**

FULL PART NUMBER:  
**RXL-3346-X02**  
DRAWN BY: Jackson Chong  
DRAWN DATE: 11/11/2019  
DO NOT SCALE DRAWING  
Scale: 1:4  
DRAWING SIZE: **B**  
SHEET 1 OF 1

| 8 | 7 | 6 | 5 | 4 | 3 | 2 | 1 |
|---|---|---|---|---|---|---|---|
|---|---|---|---|---|---|---|---|