

ITEM #	PART NUMBER	CONFIGURATION	REV	DESCRIPTION	MATERIAL	QTY
1	AS-3329-03	X04	A	04in. W Extension Hardware Assembly		1

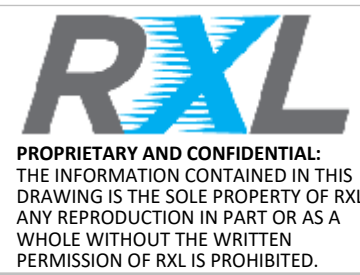
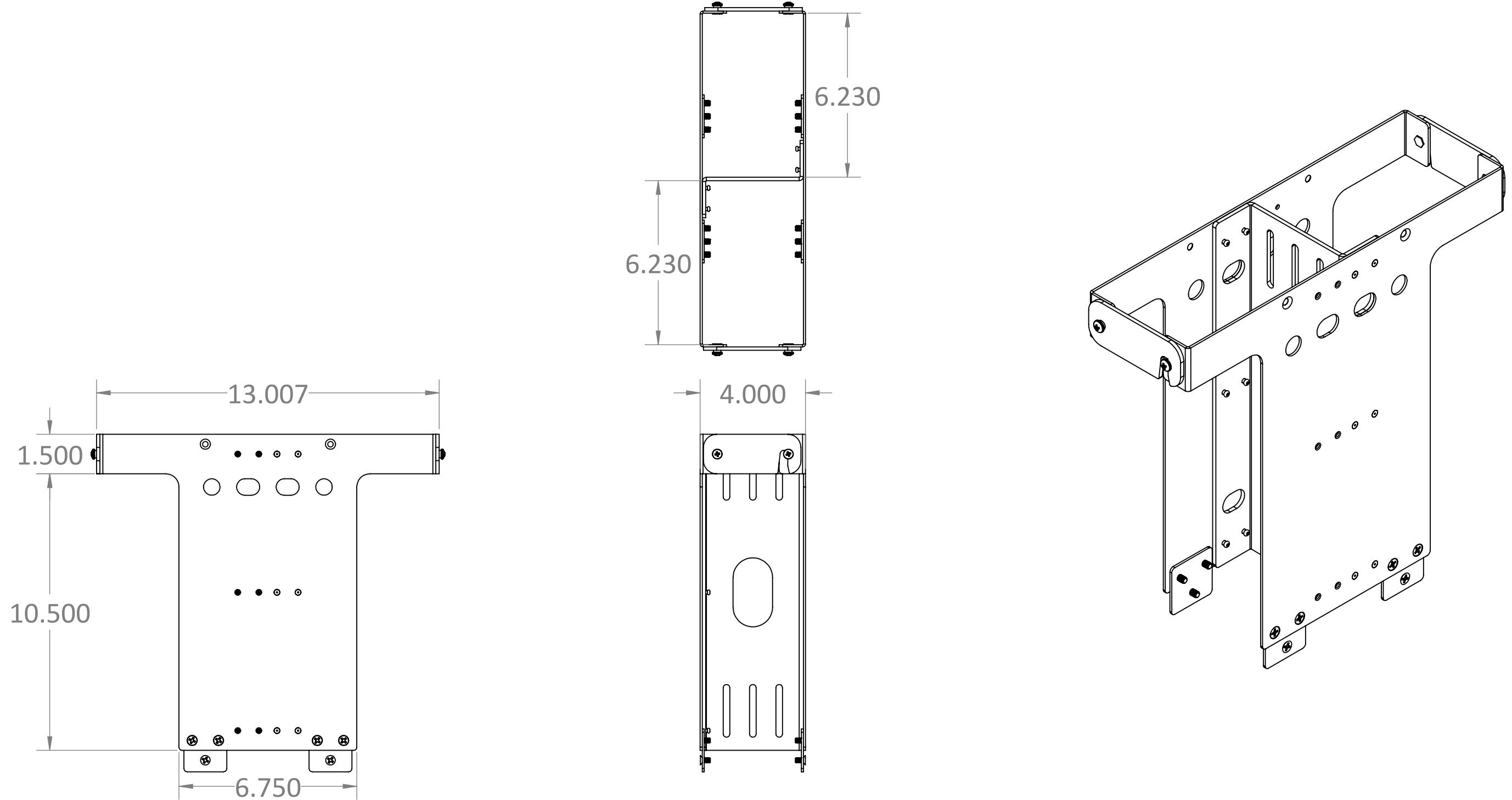

SERIES/FAMILY NUMBER: <b>RXL-3329</b>		CONFIGURATION (SEE TABLE DETAILS/"X" DENOTES COLOR): <b>X04</b>		COMMENTS/FOLDER PATH: D:\RXL Inc\RXL - Engineering - Documents\Section 3 - Cable Management\RXL-3329 Double Sided Trough Cable Manager Extension\	
DESCRIPTION: 04in. W x 1ft. H Double Sided Trough Cable Manager Extension					
REVISION <b>A</b>	DATE <b>4/2/2021</b>	REVISION DESCRIPTION: Initial			
UNLESS OTHERWISE SPECIFIED: DIMENSIONS ARE IN INCHES TOLERANCES: ±0.03 FRACTIONAL: ±1/32 ANGULAR: ±1° TWO PLACE DECIMAL ±0.03 THREE PLACE DECIMAL ±0.030		MATERIAL:  FINISH: <b>PAINT</b> WEIGHT: 2.72lbs.		SURFACE AREA: 585.94in. <sup>2</sup>	
FULL PART NUMBER: RXL-3329-X04		DRAWN BY: Jackson Chong		DRAWN DATE: 4/2/2021	
DO NOT SCALE DRAWING Scale: 1:4		DRAWING SIZE: <b>B</b> SHEET 1 OF 1			