

ITEM #	PART NUMBER	CONFIGURATION	REV	DESCRIPTION	MATERIAL	QTY
1	AS-3327-02	X04	A	04in. W Extension Hardware Assembly		1

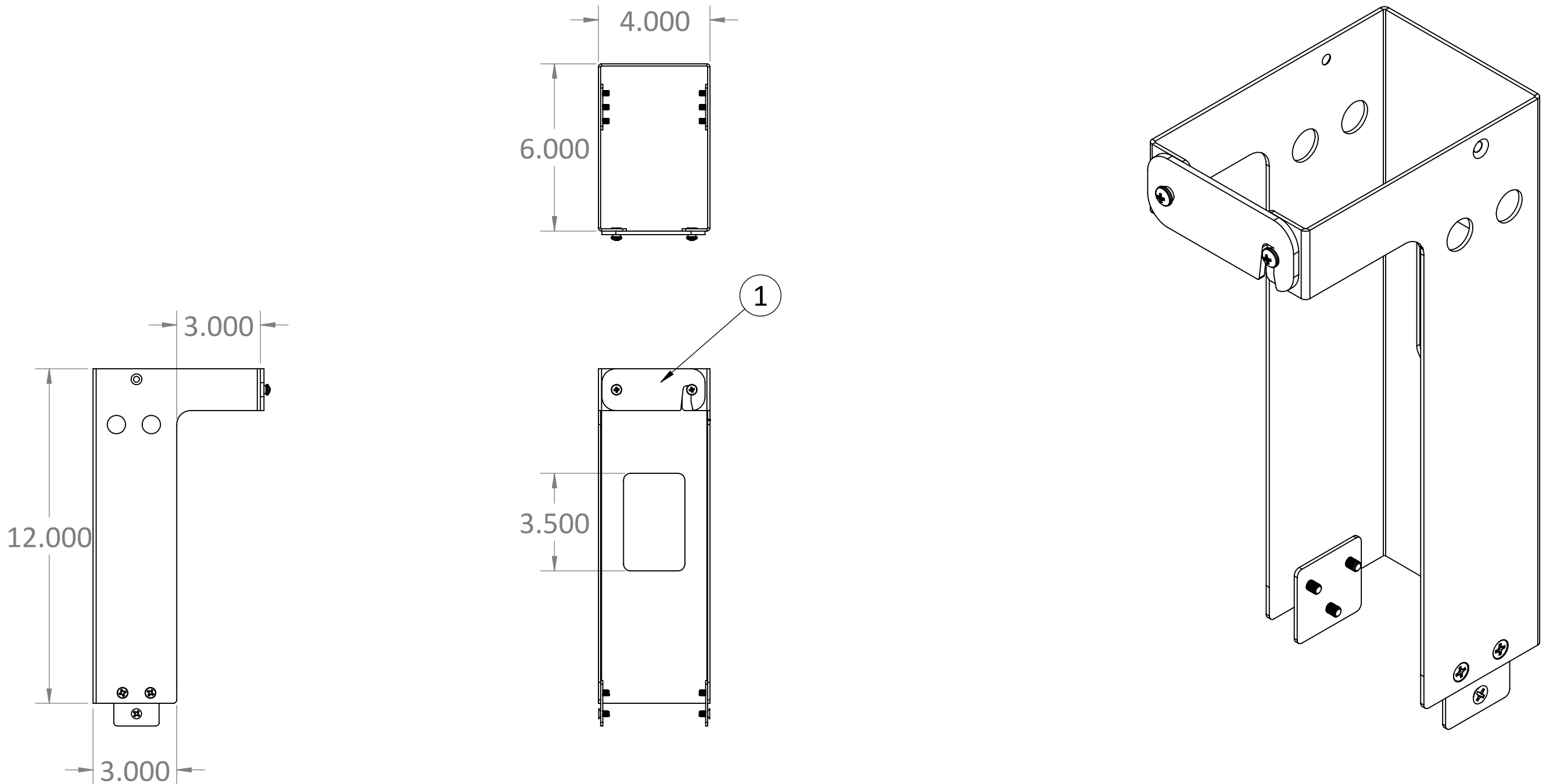

PROPRIETARY AND CONFIDENTIAL:
THE INFORMATION CONTAINED IN THIS
DRAWING IS THE SOLE PROPERTY OF RXL.
ANY REPRODUCTION IN PART OR AS A
WHOLE WITHOUT THE WRITTEN
PERMISSION OF RXL IS PROHIBITED.

SERIES/FAMILY NUMBER:
RXL-3327

DESCRIPTION:
04in. W Single Sided Trough Cable Manager Extension

REVISION
A

DATE
4/5/2021

REVISION DESCRIPTION:
Initial

CONFIGURATION (SEE TABLE DETAILS/"X" DENOTES COLOR):
X04

COMMENTS/FOLDER PATH:
B:\RXL Inc\RXL Engineering - General\RXL\Section 3 - Cable Management\RXL-3327 Single Sided Trough Cable
Manager Extension\

UNLESS OTHERWISE SPECIFIED:
DIMENSIONS ARE IN INCHES
TOLERANCES: ± 0.03
FRACTIONAL: $\pm 1/32$
ANGULAR: $\pm 1^\circ$
TWO PLACE DECIMAL ± 0.03
THREE PLACE DECIMAL ± 0.030

MATERIAL:
FINISH:
PAINT
WEIGHT:
1.14lbs.

SURFACE AREA:
274.51in.²

FULL PART NUMBER:
RXL-3327-X04

DRAWN BY: Jackson Chong
DRAWN DATE: 4/5/2021

DO NOT SCALE DRAWING
Scale: 1:4
DRAWING SIZE: **B**
SHEET 1 OF 1

8

7

6

5

4

3

2

1

A

B

C

D

E

F