

ITEM #	PART NUMBER	CONFIGURATION	REV	DESCRIPTION	MATERIAL	QTY
1	AS-2540-01	X00	A	Leveler Attachment Kit Hardware Assembly		2

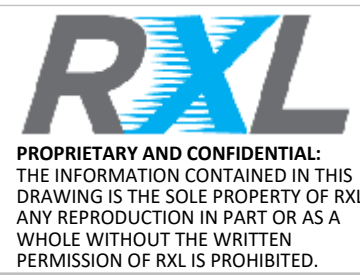
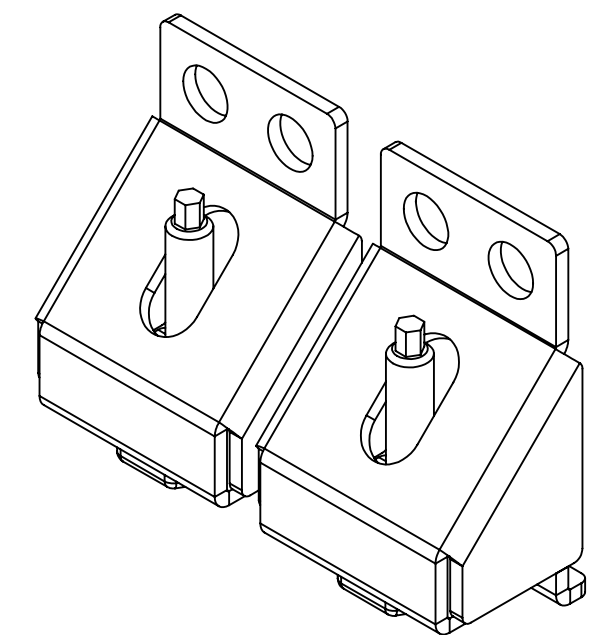
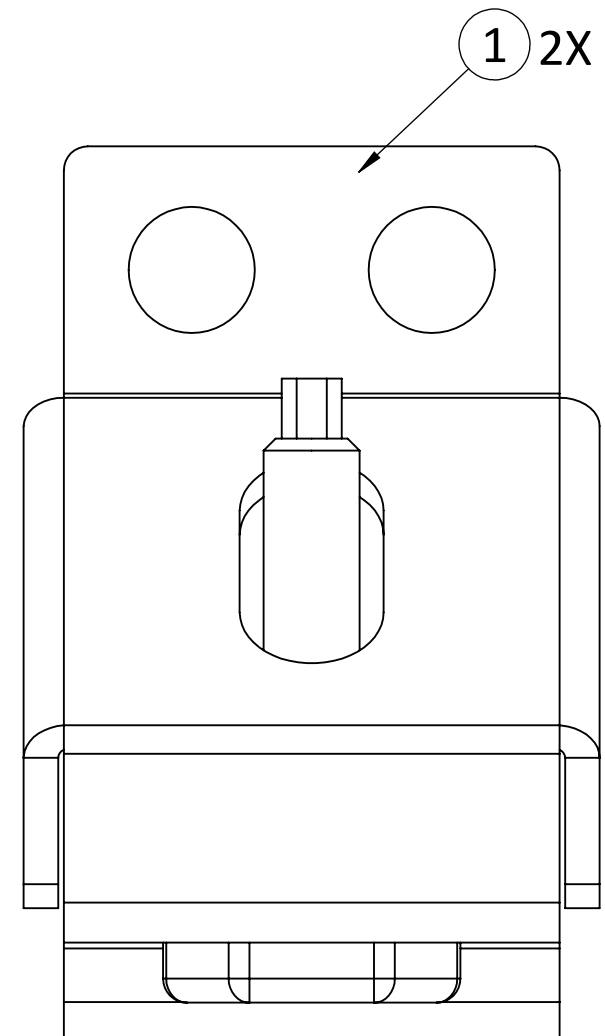
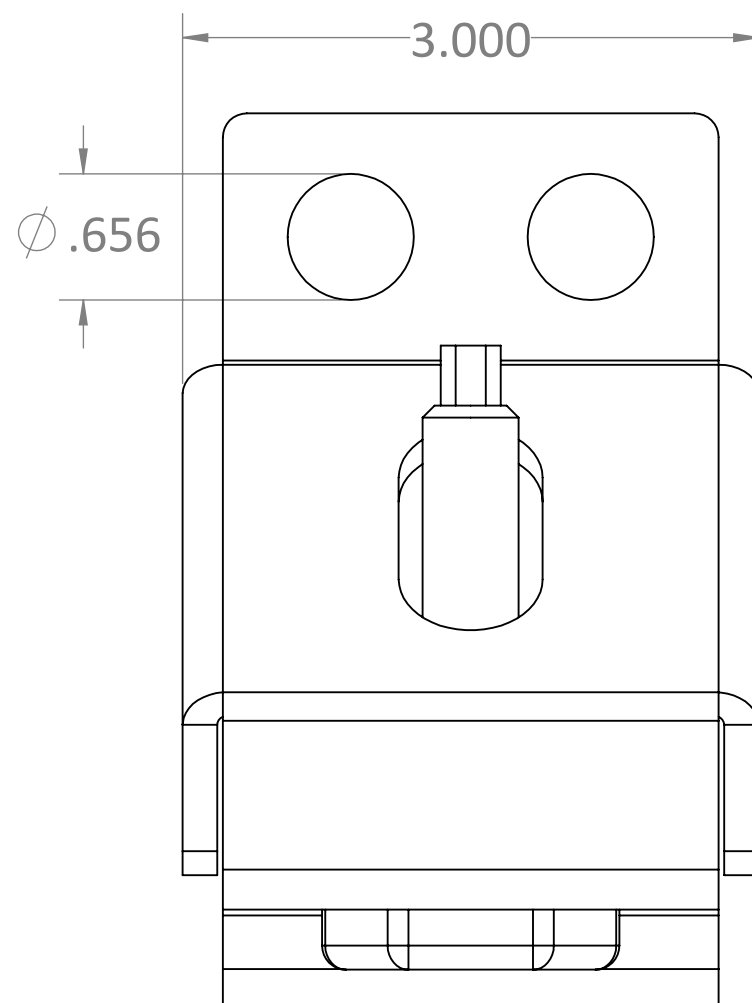
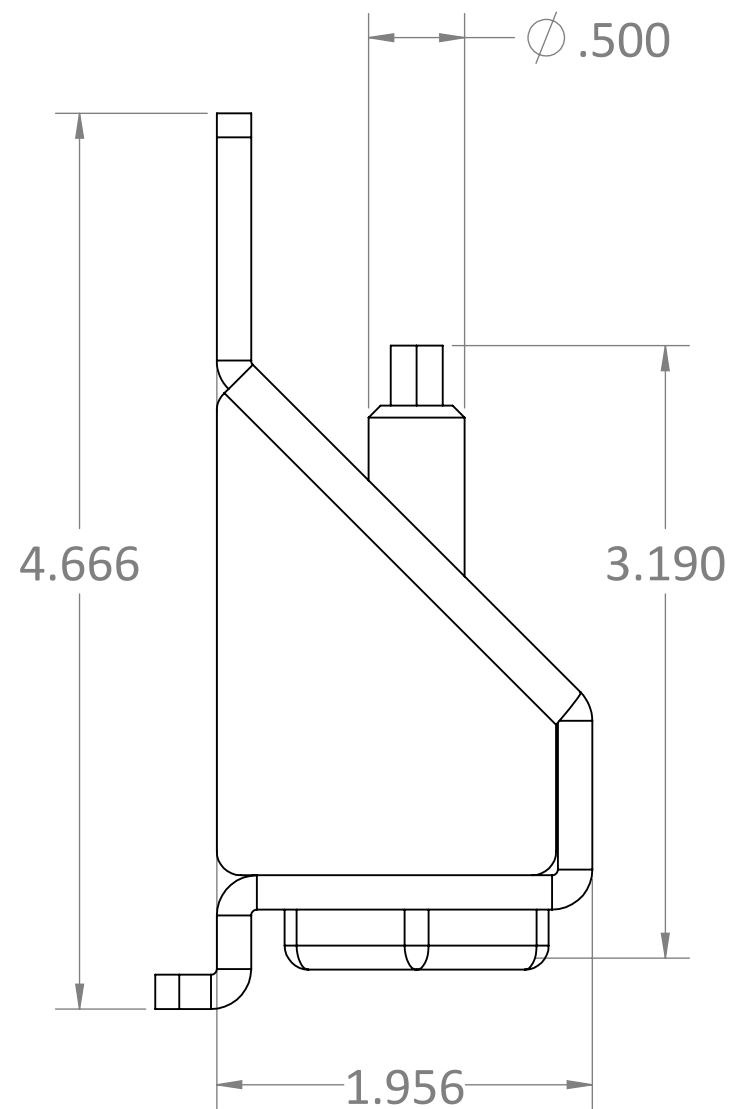

SERIES/FAMILY NUMBER: RXL-2540		CONFIGURATION (SEE TABLE DETAILS/"X" DENOTES COLOR): X01
DESCRIPTION: RXL-2540 Leveler Attachment Kit		
REVISION A	DATE 3/10/2020	REVISION DESCRIPTION: Initial

COMMENTS/FOLDER PATH: B:\RXL Inc\RXL Engineering - General\RXL\Section 2 - Open Racks\RXL-2540 Leveler Attachment Kit\
UNLESS OTHERWISE SPECIFIED: DIMENSIONS ARE IN INCHES TOLERANCES: ±0.03 FRACTIONAL: ±1/32 ANGULAR: ±1° TWO PLACE DECIMAL ±0.03 THREE PLACE DECIMAL ±0.030

MATERIAL:	FULL PART NUMBER: RXL-2540-X01
FINISH: PAINT	DRAWN BY: Jackson Chong
WEIGHT: 2.86lbs.	DRAWN DATE: 3/10/2020
SURFACE AREA: 129.03in.²	DO NOT SCALE DRAWING Scale: 1:4
	DRAWING SIZE: B SHEET 1 OF 1

8	7	6	5	4	3	2	1
---	---	---	---	---	---	---	---