

ITEM #	PART NUMBER	CONFIGURATION	REV	DESCRIPTION	MATERIAL	QTY
1	WD-1076-01	X15	B	15in. Global Cable Runway Corner Radius Brackets	Assembly	1
2	AS-1076-01	X01	B	1.5" Stringer Splice Clamp Hardware Assembly	Assembly	4

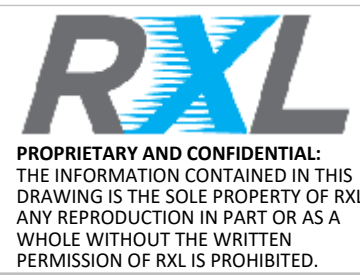
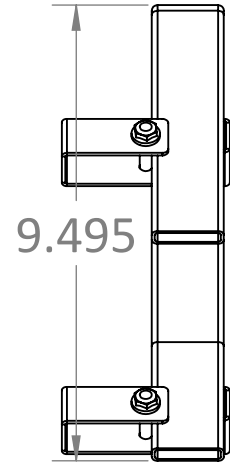
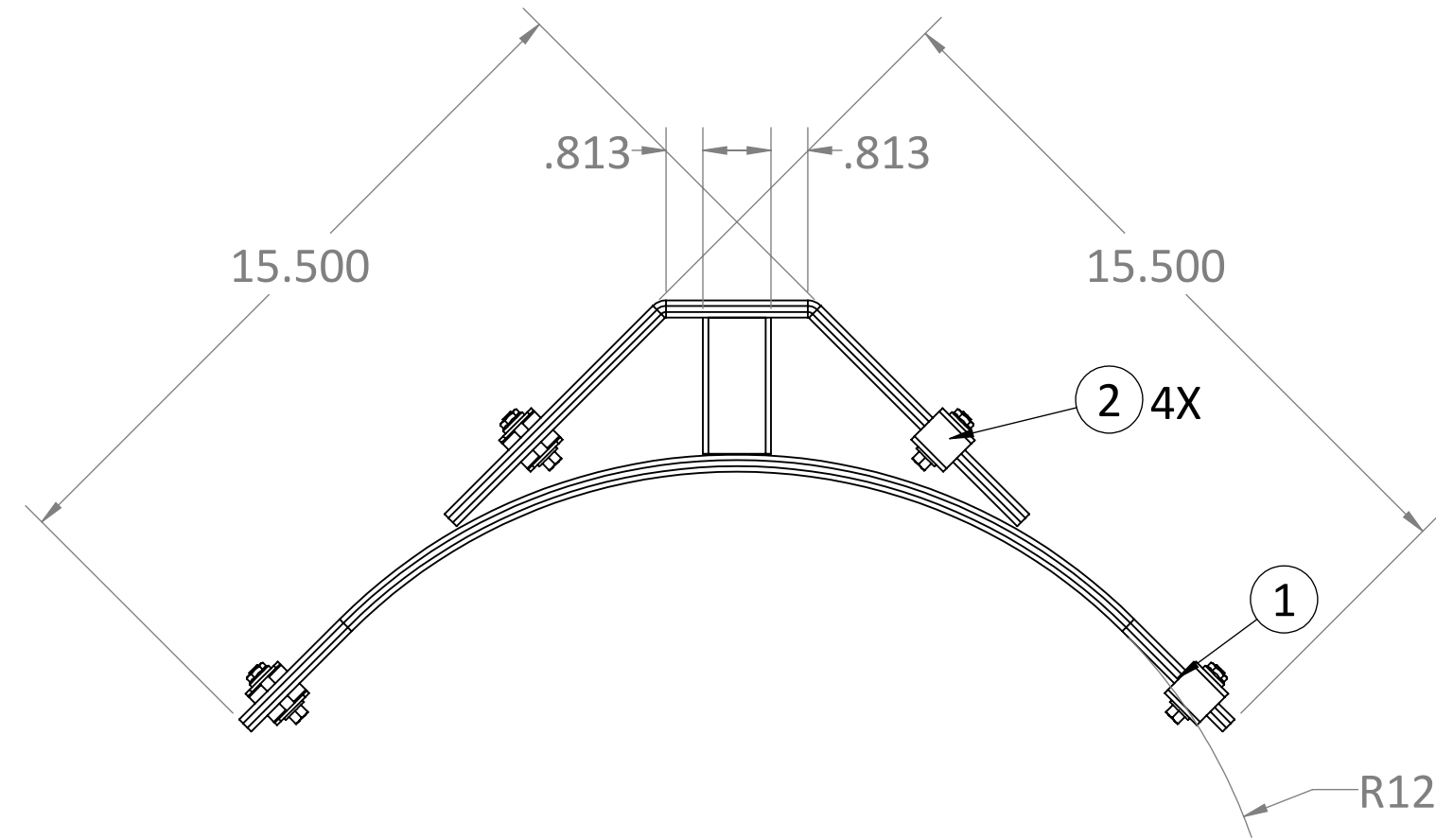
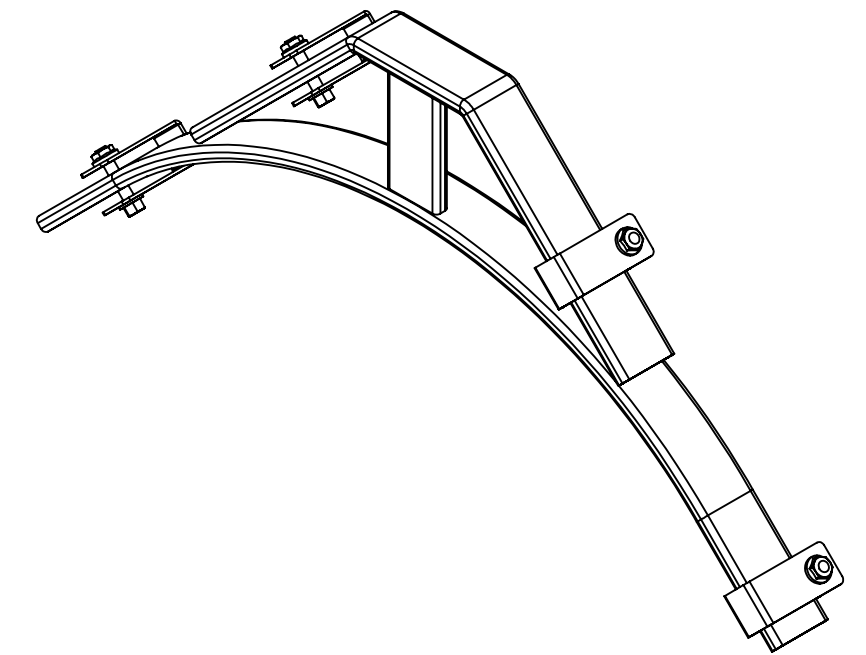
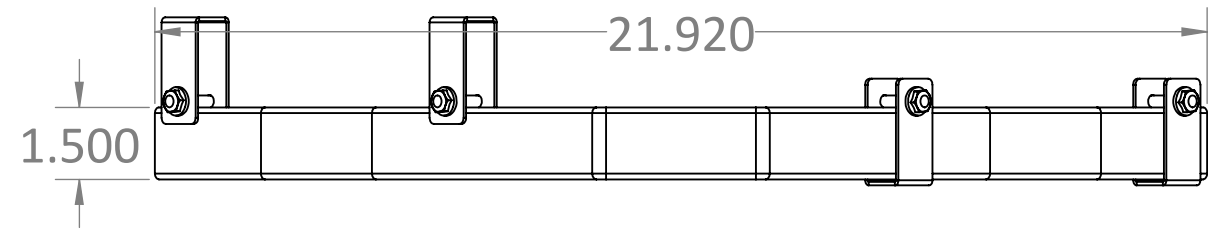

SERIES/FAMILY NUMBER: RXL-1076		CONFIGURATION (SEE TABLE DETAILS/"X" DENOTES COLOR): X15		COMMENTS/FOLDER PATH: D:\RXL Inc\RXL - Engineering - Section 1 - Cable Pathways\RXL-1076 Global Cable Runway Corner Radius Brackets\	
DESCRIPTION: 15" Global Cable Runway Corner Radius Brackets				UNLESS OTHERWISE SPECIFIED: DIMENSIONS ARE IN INCHES TOLERANCES: ±0.03 FRACTIONAL: ±1/32 ANGULAR: ±1° TWO PLACE DECIMAL ±0.03 THREE PLACE DECIMAL ±0.030	
REVISION B	DATE 2/8/2023	REVISION DESCRIPTION: Update to Radius Style, Added Clamp Bracket		MATERIAL: Assembly	FULL PART NUMBER: RXL-1076-X15
				FINISH: PAINT	DRAWN BY: DRAWN DATE: 2/8/2023
				WEIGHT:	SURFACE AREA: DO NOT SCALE DRAWING Scale: 1:8
				DRAWING SIZE: B SHEET 1 OF 1	