

ITEM #	PART NUMBER	CONFIGURATION	DESCRIPTION	MATERIAL	QTY
1	WD-1075-01	X04	E-Bend Weldment		1

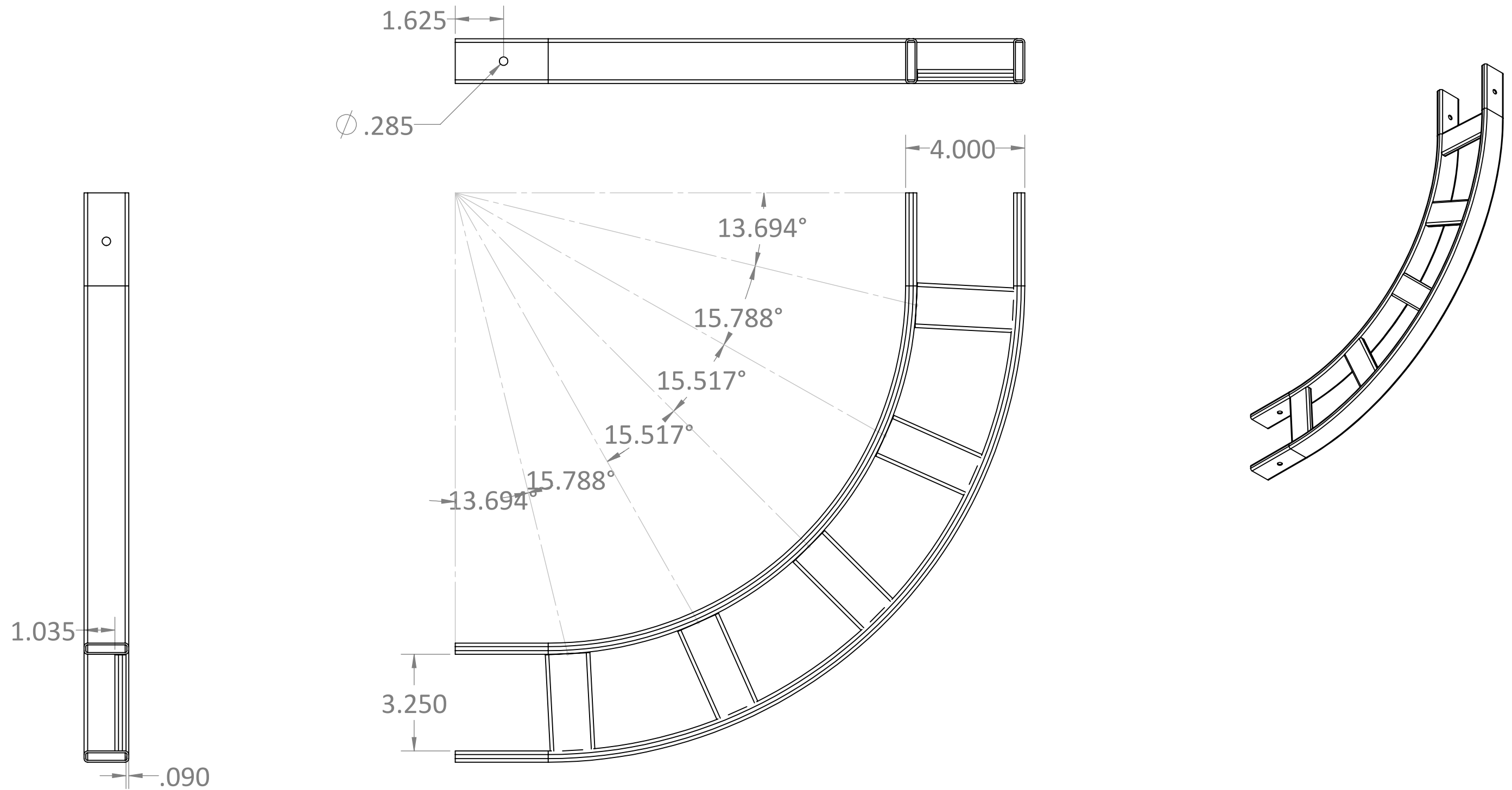

RXL
 PROPRIETARY AND CONFIDENTIAL:
 THE INFORMATION CONTAINED IN THIS
 DRAWING IS THE SOLE PROPERTY OF RXL.
 ANY REPRODUCTION IN PART OR AS A
 WHOLE WITHOUT THE WRITTEN
 PERMISSION OF RXL IS PROHIBITED.

SERIES/FAMILY NUMBER:
RXL-1075

DESCRIPTION:
E-Bends

REVISION
A

DATE
7/30/2019

REVISION DESCRIPTION:
 Initial

CONFIGURATION (SEE TABLE DETAILS/"X" DENOTES COLOR):
X04

COMMENTS/FOLDER PATH:
 B:\RXL Inc\RXL Engineering - General\RXL\Section 1 - Cable Pathways\RXL-1075 Global Cable Runway E-Bends\

UNLESS OTHERWISE SPECIFIED:
 DIMENSIONS ARE IN INCHES
 TOLERANCES: ± 0.03
 FRACTIONAL: $\pm 1/32$
 ANGULAR: $\pm 1^\circ$
 TWO PLACE DECIMAL ± 0.03
 THREE PLACE DECIMAL ± 0.030

MATERIAL:
 FINISH:
PAINT
 WEIGHT:
4.11lbs.

SURFACE AREA:
490.5in.²

FULL PART NUMBER:
RXL-1075-X04

DRAWN BY: Jackson Chong
 DRAWN DATE: 7/30/2019

DO NOT SCALE DRAWING
 Scale: 1:4
 DRAWING SIZE: **B**
 SHEET 1 OF 2

ITEM #	PART NUMBER	CONFIGURATION	DESCRIPTION	MATERIAL	QTY
1	WD-1075-01	X04	E-Bend Weldment		1

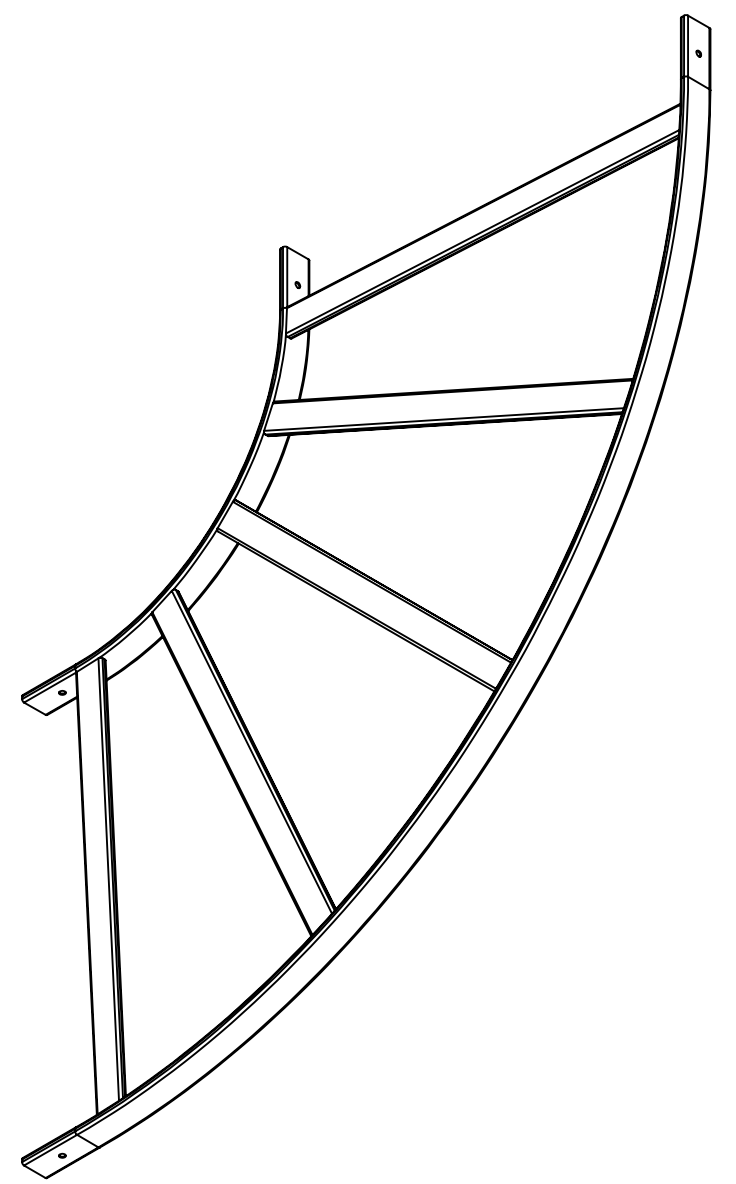
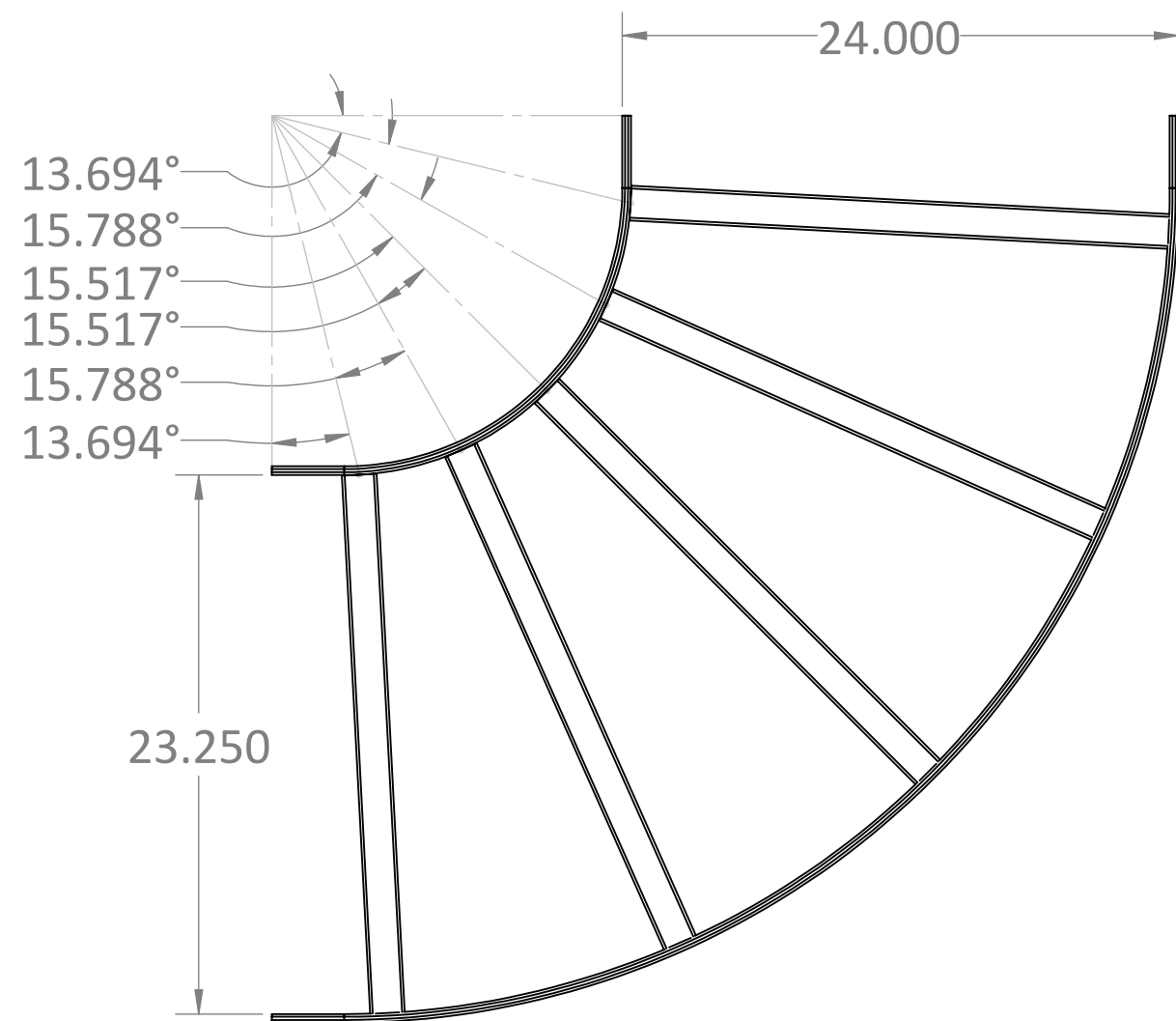
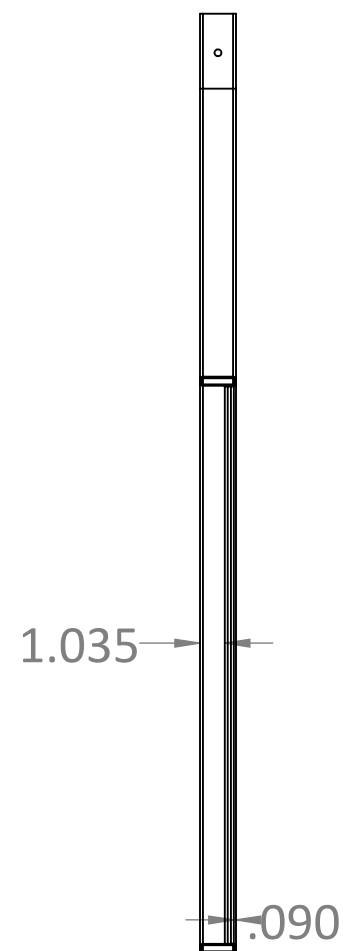
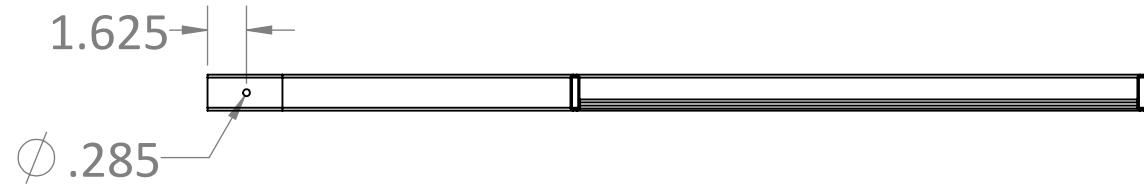

RXL
 PROPRIETARY AND CONFIDENTIAL:
 THE INFORMATION CONTAINED IN THIS
 DRAWING IS THE SOLE PROPERTY OF RXL.
 ANY REPRODUCTION IN PART OR AS A
 WHOLE WITHOUT THE WRITTEN
 PERMISSION OF RXL IS PROHIBITED.

SERIES/FAMILY NUMBER:
RXL-1075

DESCRIPTION:
E-Bends

REVISION **A** DATE **7/30/2019** REVISION DESCRIPTION:
Initial

CONFIGURATION (SEE TABLE DETAILS/"X" DENOTES COLOR):
X24

COMMENTS/FOLDER PATH:
 B:\RXL Inc\RXL Engineering - General\RXL\Section 1 - Cable Pathways\RXL-1075 Global Cable Runway E-Bends\

UNLESS OTHERWISE SPECIFIED:
 DIMENSIONS ARE IN INCHES
 TOLERANCES: ± 0.03
 FRACTIONAL: $\pm 1/32$
 ANGULAR: $\pm 1^\circ$
 TWO PLACE DECIMAL ± 0.03
 THREE PLACE DECIMAL ± 0.030

MATERIAL:
 FINISH:
PAINT
 WEIGHT:
11.54lbs.

SURFACE AREA:
1372.78in.²

FULL PART NUMBER:
RXL-1075-X24
 DRAWN BY: Jackson Chong
 DRAWN DATE: 7/30/2019
 DO NOT SCALE DRAWING Scale: 1:4 DRAWING SIZE: **B**
 SHEET 2 OF 2